

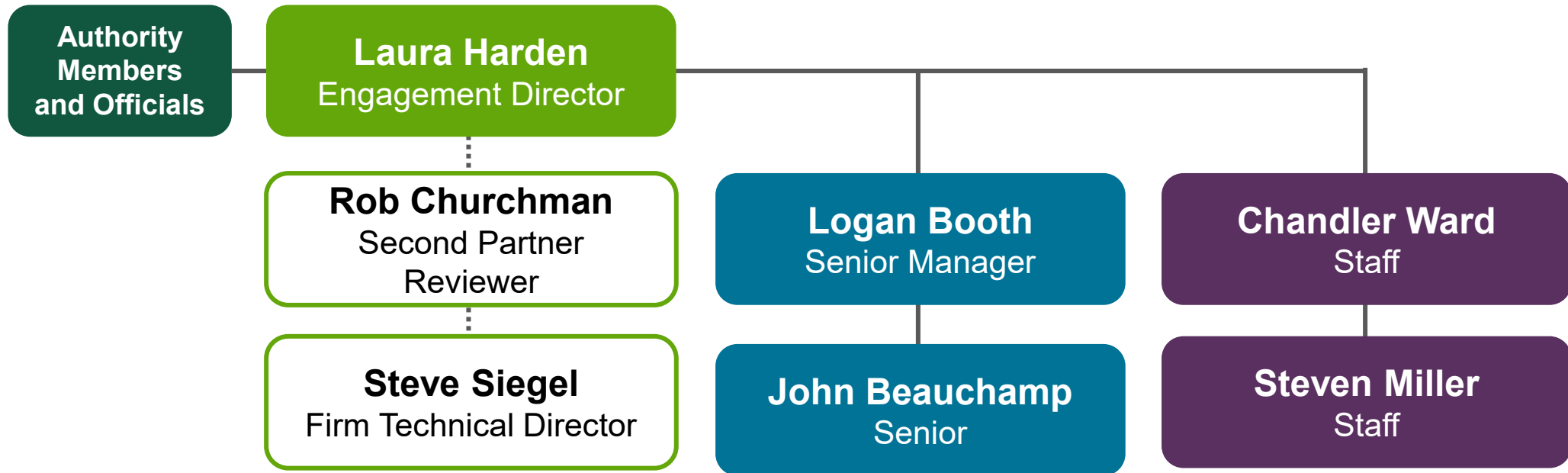

City of Virginia Beach Development Authority  
**Audit Executive Summary**

# Client Service Team





# Agenda

- ▶ Results of the Audit
- ▶ Corrected and Uncorrected Misstatements
- ▶ Required Communications
- ▶ Other Matters
- ▶ Reporting Changes

This information is intended solely for the use of the Board of Commissioners of the City of Virginia Beach Development Authority and management and is not intended to be, and should not be, used by anyone other than these specified parties.



# Results of the Audit

## Financial Statements:

- We have audited the financial statements of the City of Virginia Beach Development Authority (the “Authority”), as of and for the year ended June 30, 2022, and we have issued our report thereon dated March 8, 2023.
- We have issued an unmodified opinion on the financial statements.

## Compliance:

- We identified no instances of noncompliance required to be reported under *Government Auditing Standards* or the *Specifications for Audits of Authorities, Boards, and Commissions*.
- We identified no material weaknesses in internal control over financial reporting.

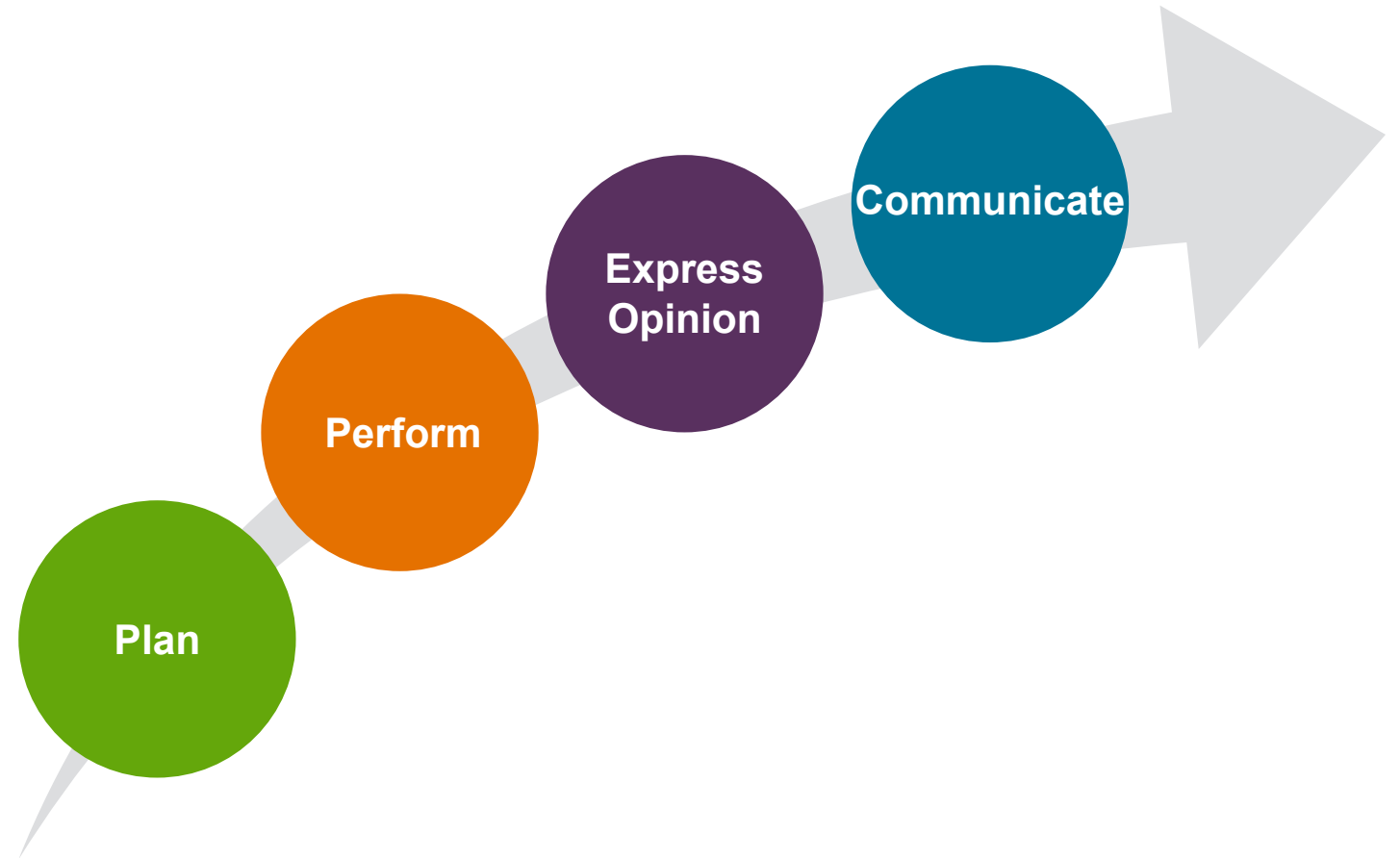



# Corrected and Uncorrected Misstatements

Professional standards require us to accumulate all misstatements identified during the audit, other than those that are clearly trivial, and communicate them to the appropriate level of management.

## Corrected Misstatements

▶ None noted.

## Uncorrected Misstatements

▶ None noted.



# Qualitative Aspects of Accounting Practices

Management is responsible for the selection and use of appropriate accounting policies. The significant accounting policies used by the Authority are described in Note 1 to the financial statements.

As described in Note 6, the Authority changed accounting policies related to leases by adopting Government Accounting Standards Board (“GASB”) Statement No. 87, *Leases*, effective July 1, 2021.

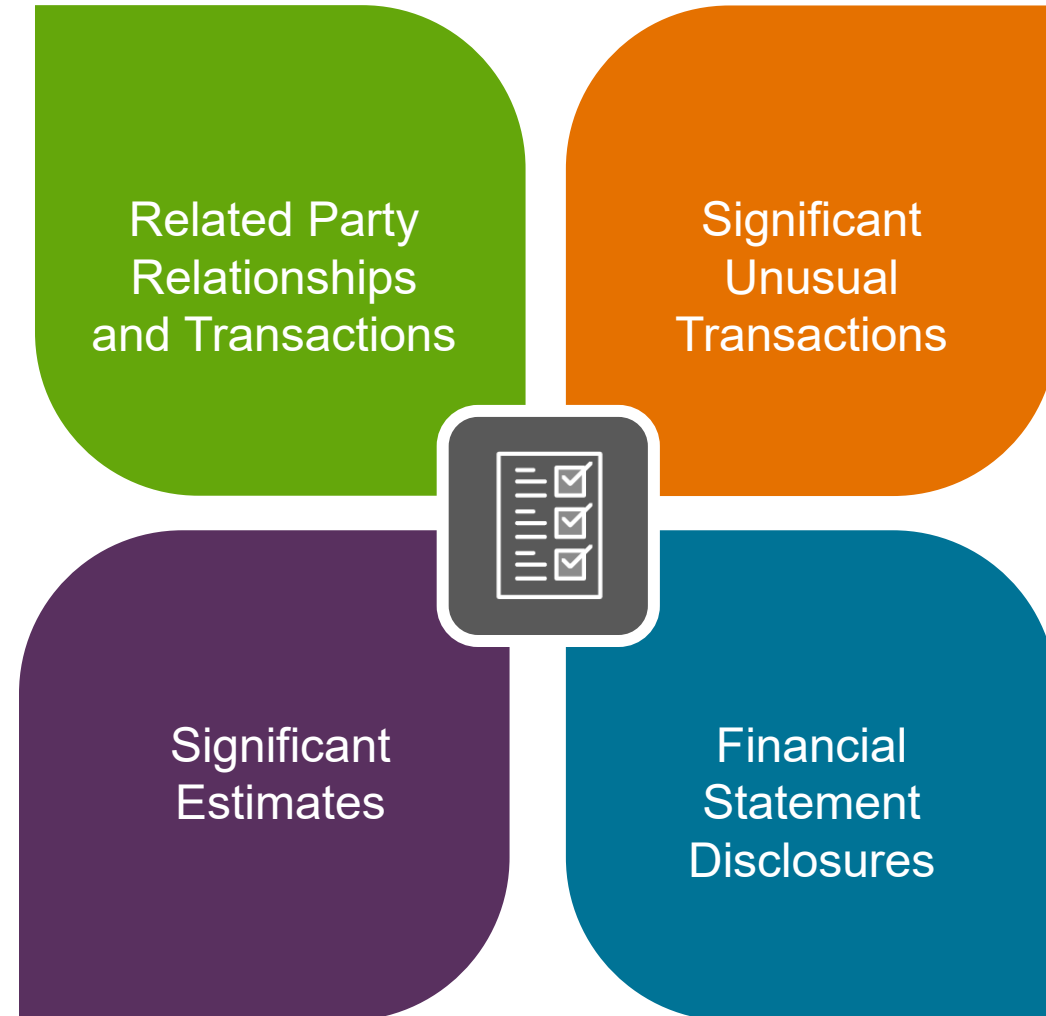

# Qualitative Aspects of Accounting Practices

As part of our audit, we evaluated the Authority's identification of, accounting for, and disclosure of the Authority's relationships and transactions with related parties as required by professional standards.

We noted none of the following:

- Related parties or related party relationships or transactions that were previously undisclosed to us;
- Significant related party transactions that have not been approved in accordance with the Authority's policies or procedures or for which exceptions to the Authority's policies or procedures were granted;
- Significant related party transactions that appeared to lack a business purpose;
- Noncompliance with applicable laws or regulations prohibiting or restricting specific types of related party transactions;
- Difficulties in identifying the party that ultimately controls the entity.

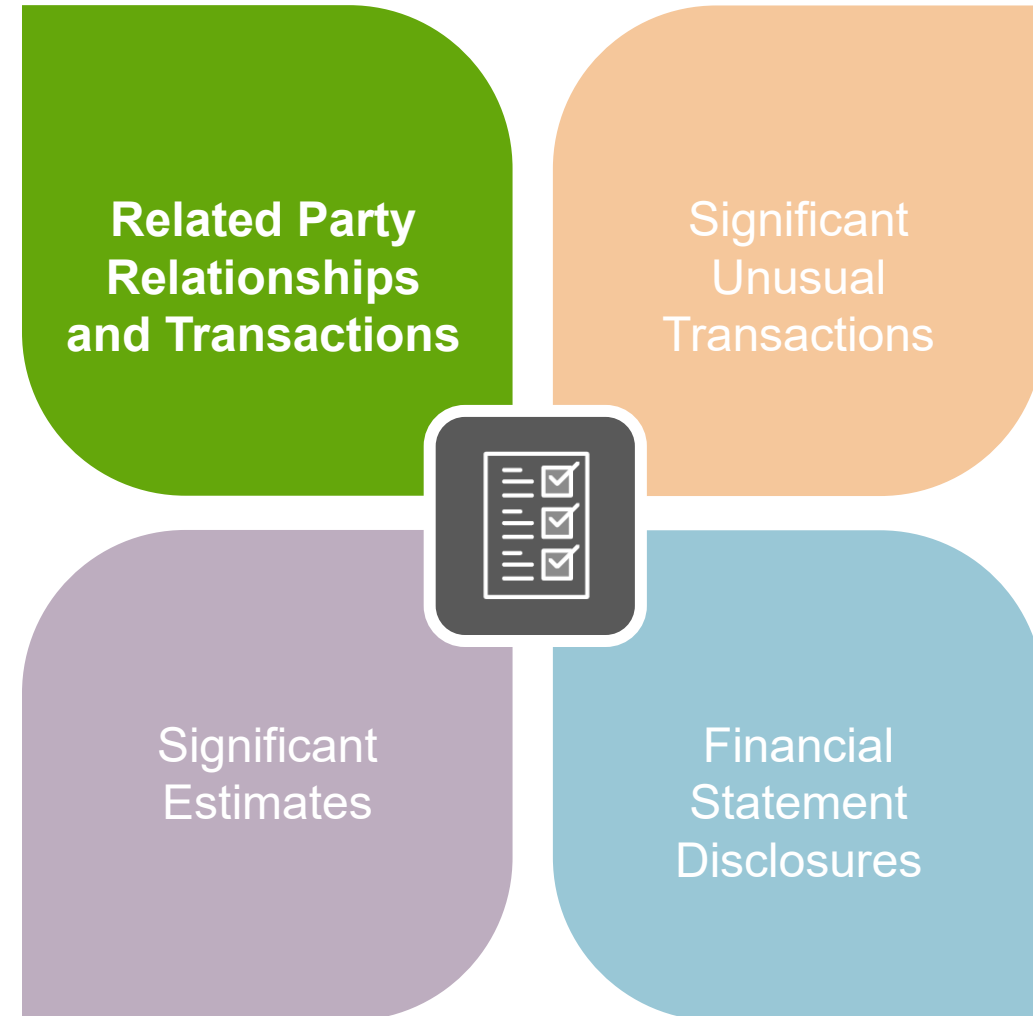

# Qualitative Aspects of Accounting Practices

We noted no transactions entered into by the Authority during the year for which there is a lack of authoritative guidance or consensus. All significant transactions have been recognized in the financial statements in the proper period.

For purposes of this letter, professional standards define significant unusual transactions as transactions that are outside the normal course of business for the Authority or that otherwise appear to be unusual due to their timing, size or nature. We noted no significant unusual transactions during our audit.

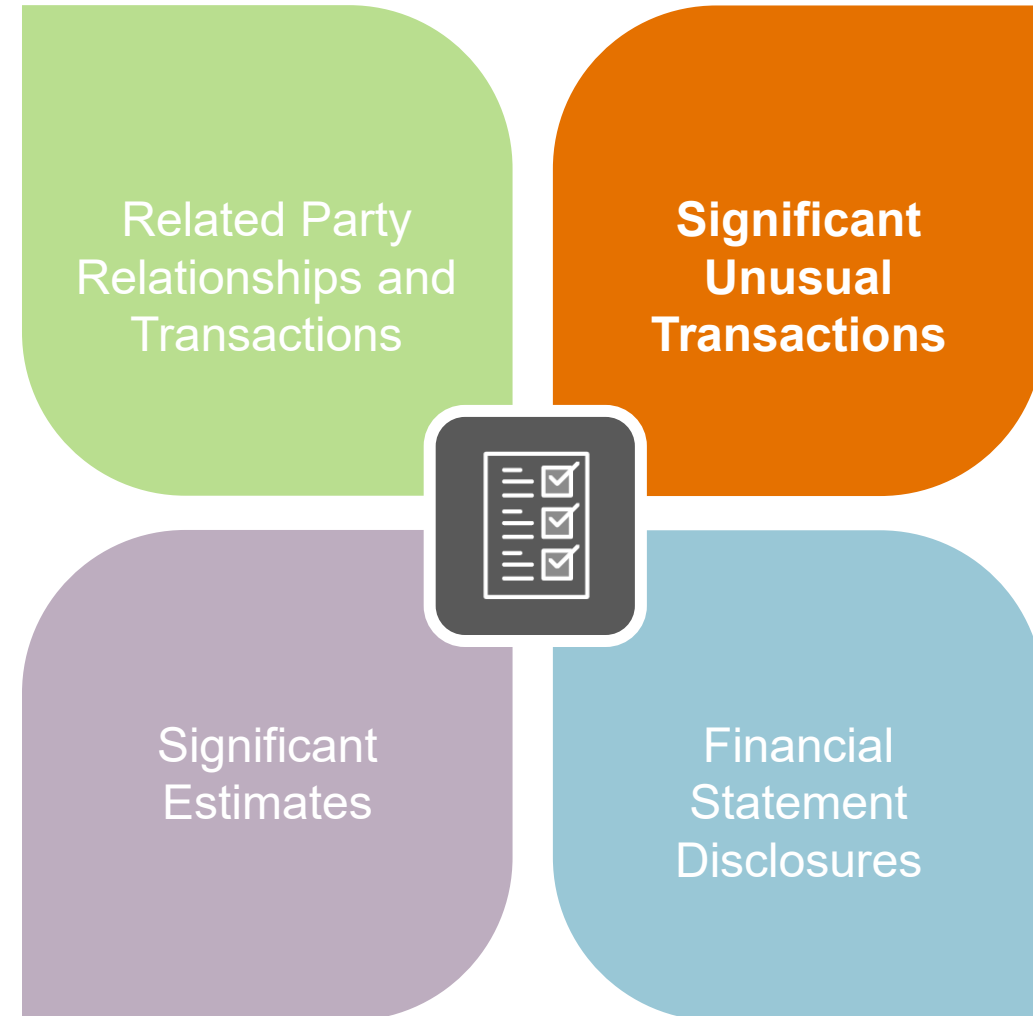

# Qualitative Aspects of Accounting Practices

Accounting estimates are an integral part of the financial statements prepared by management and are based on management's knowledge and experience about past and current events and assumptions about future events. Certain accounting estimates are particularly sensitive because of their significance to the financial statements and because of the possibility that future events affecting them may differ significantly from those expected. The most sensitive estimate affecting the financial statements was:

Management's estimate of land held for resale is based on the acquisition cost plus improvements, not to exceed the net realizable value. We evaluated the key factors and assumptions used to develop the land held for resale in determining that it is reasonable in relation to the financial statements taken as a whole.

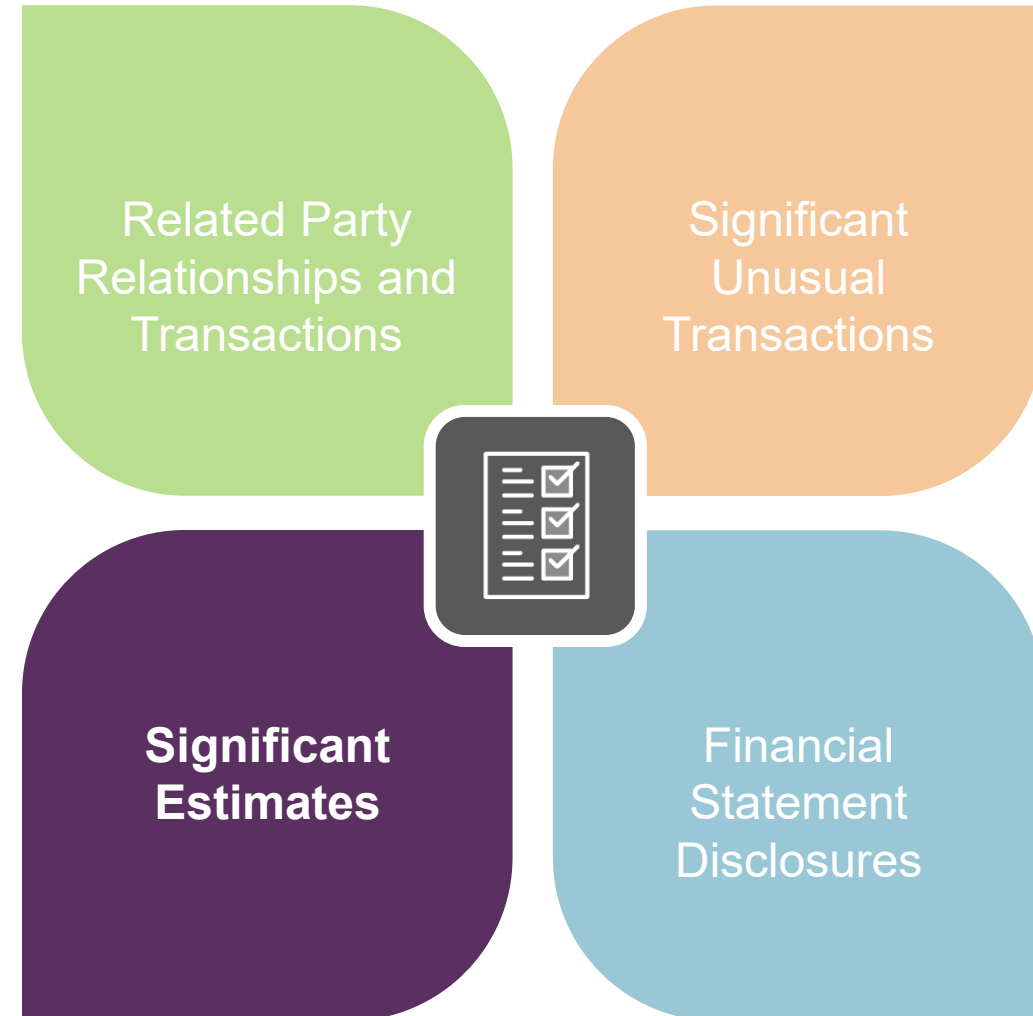

# Qualitative Aspects of Accounting Practices

The financial statement disclosures are neutral, consistent, and clear.

Certain financial statement disclosures are particularly sensitive because of their significance to financial statement users. The most sensitive disclosure affecting the financial statements was:

The disclosure of *Leases Receivables and Deferred Inflows* in Note 6 of the financial statements discloses the Authority's account balances associated with its leases including leases receivable, deferred inflows, and lease revenue under GASB 87.

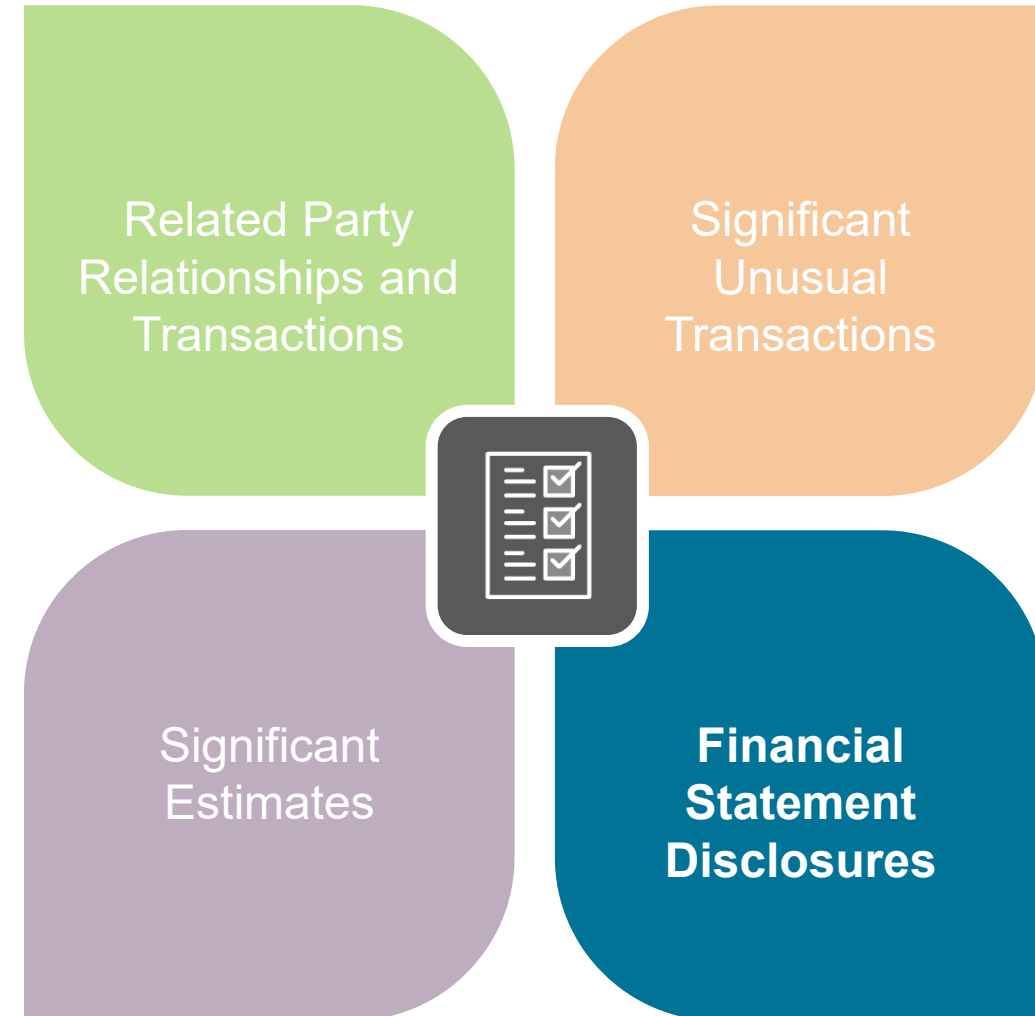

# Independence Considerations

## Nonattest Services

- ▶ Our firm did not perform any nonattest services for the Authority.

## Independence Conclusion

- ▶ We are not aware of any other circumstances or relationships that create threats to auditor independence.
- ▶ We are independent of the Authority and have met our other ethical responsibilities in accordance with the relevant ethical requirements relating to our audits.





# Other Required Communications

## Difficulties Encountered

We encountered no significant difficulties in dealing with management in performing and completing our audit.

## Disagreements with Management

Includes disagreements on a financial accounting, reporting, or auditing matter, whether or not resolved to our satisfaction, that could be significant to the financial statements or the auditor's report.

We are pleased to report that no such disagreements arose during the course of our audit.

## Auditor Consultations

We noted no matters that are difficult or contentious for which the auditor consulted outside the engagement team.

## Management Representations

We have requested certain representations from management that are included in the management representation letter dated the date of our audit report.



# Other Required Communications

## Management Consultations

In some cases, management may decide to consult with other accountants about auditing and accounting matters, similar to obtaining a “second opinion” on certain situations.

To our knowledge, there were no such consultations with other accountants.

## Other Findings or Issues

We generally discuss a variety of matters, including the application of accounting principles and auditing standards, with management each year.

These discussions occurred in the normal course of our professional relationship and our responses were not a condition to our retention.

## Fraud and Illegal Acts

As of the date of this presentation no fraud, illegal acts, or violations of laws and regulations noted.

## Going Concern

No events or conditions noted that indicate substantial doubt about the entity’s ability to continue as a going concern.



# Other Matters

## Required Supplementary Information

With respect to the management's discussion and analysis accompanying the financial statements, we have applied certain limited procedures to the required supplementary information in accordance with generally accepted auditing standards, which consisted of inquiries of management about the methods of preparing the information and comparing the information for consistency with management's responses to our inquiries, the basic financial statements, and other knowledge we obtained during our audit of the basic financial statements. We do not express an opinion or provide any assurance on the information.



## Supplemental Information

With respect to Supplementary Information – Schedules accompanying the financial statements, the information has been subjected to the auditing procedures applied in the audits of the basic financial statements and certain additional procedures, including comparing and reconciling such information directly to the underlying accounting and other records used to prepare the basic financial statements or to the basic financial statements themselves, and other additional procedures in accordance with auditing standards generally accepted in the United States of America. In our opinion, the Supplementary Information – Schedules is fairly stated, in all material respects, in relation to the basic financial statements as a whole.



# Other Matters

## Other Information

The Introductory Section has not been subjected to the auditing procedures applied in the audit of the basic financial statements and, accordingly, we do not express an opinion or provide any assurance on it.



# Upcoming Financial Reporting Changes

These standards will be effective for the Authority in the upcoming years and may have a significant impact on the Authority's financial reporting.

We would be happy to discuss with management the potential impacts on the Authority's financial statements and how we may be able to assist in the implementation efforts.

GASB 96 -  
Subscription-based  
Information  
Technology  
Arrangements



# Questions?

## Contacts

**Laura Harden, CPA**

*Audit Director*

lharden@cbh.com

**Logan Booth, CPA**

*Audit Senior Manager*

lbooth@cbh.com

#### **About Cherry Bekaert**

2022 Cherry Bekaert. All Rights Reserved. This material has been prepared for general informational purposes only and is not intended to be relied upon as tax, accounting, or other professional advice. Before taking any action, you should consult a professional advisor familiar with your particular facts and circumstances.



CBH.com



An aerial photograph of Virginia Beach, Virginia, taken at sunset. The sky is a mix of orange, yellow, and blue. In the center, a tall, modern skyscraper with a pointed top is illuminated. To its right, a large, multi-story building with a prominent tower is also lit up. The city streets are visible, with cars and lights. A teal-colored rectangular box is overlaid on the left side of the image, containing white text.

# VBDA Monthly Cash Flow

City of Virginia Beach Development Authority

March 21, 2023



# Operating Account Summary: February 2023

**Beginning Cash – February 1, 2023**

**\$ 2,555,491**

## **Significant Cash Receipts**

- **Grand Total of Significant Cash Receipts - \$850,709**
  - ✓ **\$694,392** Reimbursement for Amphitheater Roof Replacement from City
  - ✓ **\$114,016** Vanguard Landing for Loan Payment
  - ✓ **\$ 24,960** Atlantic Park/Dome Site Reimbursement from City
  - ✓ **\$ 17,341** Interest Income

## **Significant Cash Disbursements**

- **Grand Total of Significant Cash Disbursements - \$160,493**
  - ✓ **\$ 14,055** Kimley Horn – Atlantic Park Offsite Work – Reimbursable

# Cont. Operating Account Summary: February 2023

## Cont. Significant Cash Disbursements

- ✓ **\$146,438** W.M. Jordan Company, Inc. – Atlantic Park Offsite Infrastructure– Reimbursable

---

**Ending Cash – February 28, 2023**

**\$ 3,139,255**

# Incentive & Initiative Account Summary: February 2023

**Beginning Cash – February 1, 2023** **\$2,645,647**

## Significant Cash Receipts

**Grand Total of Significant Cash Receipts - \$396,382**

- ✓ \$ 449 Bank interest income
- ✓ \$395,933 EDIP CIP Drawdown Funds

## Significant Cash Disbursements

• **Grand Total of Significant Cash Disbursements - \$10,923**

- ✓ \$ 10,923 Olympia Bendix-Two – Bio Accelerator Monthly Rent – January 2023

**Ending Cash – February 28, 2023**

**\$3,030,929**

# EDIP Grant Summary Reporting: February 2023

<b>Beginning VBDA EDIP Grant Balance</b>	<b>\$3,595,771</b>
<b>Earned Interest and Activity Analysis Fee</b>	<b>+\$ 21</b>
<b>EDIP Grants Expired (Closed)</b>	<b>+\$ 0</b>
<b>New Grants Approved by VBDA</b>	<b><u>-\$ 0</u></b>
<b>EDIP Grant Funds Available as of Feb. 2023</b>	<b>\$3,595,792</b>

# Façade Improvement Grants (FIG)

City of Virginia Beach  
Development Authority

March 21, 2023

Presenter: Svetla Tomanova



# Overview

- Matching grant program to provide support to small, locally owned, and operated businesses located in any commercial or industrial zoned area within the City of Virginia Beach.
- Funding for impactful **exterior** building or site improvements
- Program budget for FY23: \$119,446\*
- Minimum awards: \$1,000 maximum: \$10,000
- Performance-based; within 6 months of approval

\*\$19,446 from previous FY22





# FY22 Awards Summary – Funds Remaining: \$19,446

Description	Project Address	Approval Date	Extention Request Date	Expiration Date	Capital Investment Minimum	Approved Grant Amount	Actual Private Investment	Grant Amount Paid	Date of Reimbursement	NOTES
Ava Marie Salon and Spa LLC	1860 LASKIN RD STE 119	3/15/2022		9/15/2022	\$4,786	\$ 2,393	\$ 3,788.50	\$ 1,894.25	9/1/2022	Complete
Bar-K Park LLC t/a Pups and Pints	2413 London Bridge Rd	3/15/2022	8/15/2022	11/15/2022	\$20,000	\$ 10,000	\$ 27,000.00	\$ 10,000.00	12/15/2022	Extension
Davis Advertising Inc t/a Davis Ad Agency	3200 Pacific Ave	3/15/2022		9/15/2022	\$7,706	\$ 3,853	\$ 9,020.88	\$ 3,853.00	4/20/2022	Complete
A Touch of Class Catering Inc. t/a Grand Affairs Catering	2036 Pleasure House Road	3/15/2022		9/15/2022	\$11,212	\$ 5,606	\$ 17,775.04	\$ 5,606.00	5/18/2022	Complete
Jars of Dust LLC	808 15th St	3/15/2022	8/9/2022	11/15/2022	\$15,480	\$ 7,740	\$ 11,431.00	\$ 5,715.50	11/28/2022	Complete
Jim White Fitness & Nutrition, Inc.	848 First Colonial Road	3/15/2022	6/23/2022	11/15/2022	\$9,220	\$ 4,610	\$ 10,089.00	\$ 4,610.00	10/11/2022	Complete
Katherine Holdings LLC t/a Anderton Enterprises, Inc.	2900 Shore Drive 23451	3/15/2022		9/15/2022	\$20,000	\$ 10,000	\$ 16,155.00	\$ 8,077.50	6/16/2022	Complete
Koch Development Corporation t/a Cutty Sark Motel and Cottages	205 37th Street	3/15/2022	8/18/2022	11/15/2022	\$11,000	\$ 5,500	\$ 13,186.36	\$ 5,500.00	10/11/2022	Complete
Hara, Inc. t/a Lost Planet	1930C Atlantic Ave	3/15/2022		9/15/2022	\$10,136	\$ 5,068	\$ 10,003.69	\$ 5,001.85	10/11/2022	Complete
May's Parlor LLC	2708 Pacific Avenue	3/15/2022		9/15/2022	\$9,066	\$ 4,533				Expired
Mizuno Inc. t/a Mizuno Restaurant	1860 LASKIN ROAD SUITE 115B, VIRGINIA BEACH, VA	3/15/2022		9/15/2022	\$13,280	\$ 6,640				Expired
The Sweet Spot VB LLC	5216 Providence Road	3/15/2022		9/15/2022	\$20,000	\$ 10,000	\$ 26,780.00	\$ 10,000.00	5/18/2022	Complete
Virginia Coast Restaurant Group LLC t/a Elevesens Fresh Table & Bar	328 Laskin Road	3/15/2022		9/15/2022	\$20,000	\$ 10,000	\$ 363,808.85	\$ 10,000.00	4/20/2022	Complete
Virginia George Co., Inc, t/a Dough Boy's	1700 Atlantic Avenue	3/15/2022		9/15/2022	\$16,890	\$ 8,445	\$ 12,096.00	\$ 6,048.00	8/16/2022	Complete
Waves Motel Inc.	1312 Atlantic Ave.	3/15/2022		9/15/2022	\$20,000	\$ 10,000	\$ 207,203.65	\$ 10,000.00	5/18/2022	Complete
Cutezma Corp., t/a Froggies	3656 Shore Drive	4/19/2022		10/19/2022	\$ 20,000.00	\$ 10,000.00	\$ 83,094.95	\$ 10,000.00	9/15/2022	Complete
North End Bag Co.	607 19th Street	4/19/2022		10/19/2022	\$ 5,512.00	\$ 2,756.00	\$ 5,511.68	\$ 2,756.00	10/11/2022	Complete
Oyster Cove Boatworks & Yacht Brokerage Inc.	1309 Va Beach Blvd.	4/19/2022	10/19/2022	12/19/2022	\$ 20,000.00	\$ 10,000.00	\$ 17,272.00	\$ 8,636.00	1/6/2023	Complete
B.H. Lewis Enterprises Inc., t/a Town Center City Club	222 Central Park Ave	4/19/2022		10/19/2022	\$ 11,994.00	\$ 5,997.00	\$ 16,955.00	\$ 5,997.00	8/1/2022	Complete
<b>19</b>				TOTALS	\$266,282	\$133,141	<b>\$851,172</b>	<b>\$113,695</b>		



# FIG SELECTION PROCESS

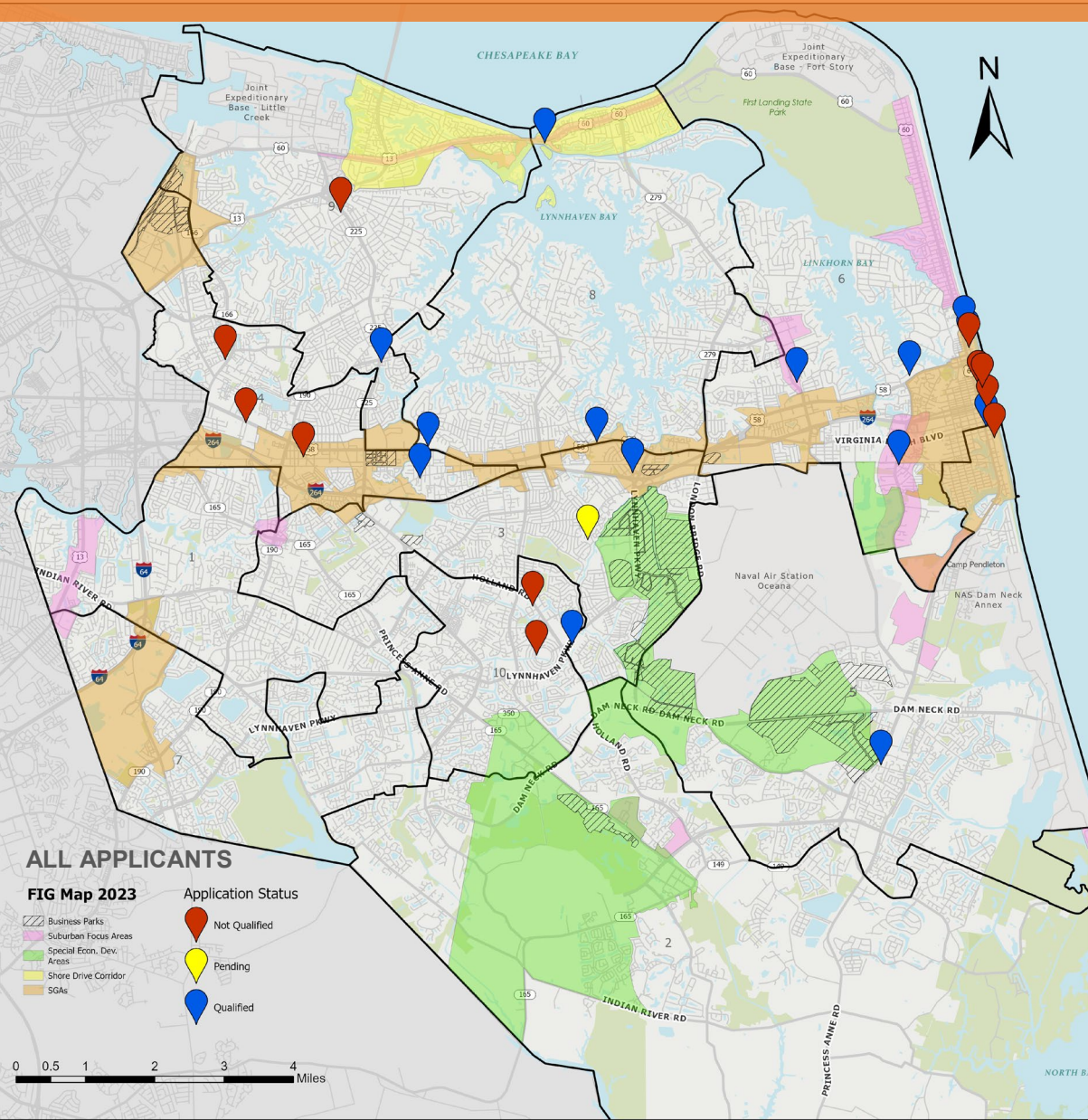

- 26 total applications received since Jan. 17
- Applications ranked by:
  - ✓ Completeness of application (1 point)
  - ✓ Business eligibility (1 point)
  - ✓ Proposed improvements eligibility (1 point)
  - ✓ Business SWaM / veteran status (1 point)
- Grant Review Committee met March 13, 2023, recommended 15 to be advanced for VBDA approval
- Requests total: \$119,385
- Funds available: \$119,446
- Estimated Façade Investment: \$463,145



# RECOMMENDED APPLICATIONS (14)

1. Cosmo's Corner, Inc. - \$10,000
2. Ray Rays at the Mayflower, LLC - \$10,000
3. Aligned Chiropractic and Wellness - \$2,697
4. Mal-Bun Properties & Bunn Insurance Agency, Inc. - \$9,400
5. 1<sup>st</sup> Class Assets - \$10,000
6. Koch Development Corporation - \$5,550
7. The Lesner Inn Catering Club, LLC - \$10,000
8. Lakeshore Property, LLC - \$9,900
9. Dan Miller & Associates dba Law Offices of Daniel J. Miller - \$ 10,000
10. Wealth Avenue - \$ 1,932
11. Assisi Medical Services dba Veterinary Hospital of Virginia Beach - \$10,000
12. Lynnhaven International, LLC - \$10,000
13. Jim White Fitness & Nutrition, Inc. dba Jim White Fitness Studios - \$3,844
14. Pacific Moon Sun, LLC dba Koco Korean Fried Chicken & Croffles - \$6,061

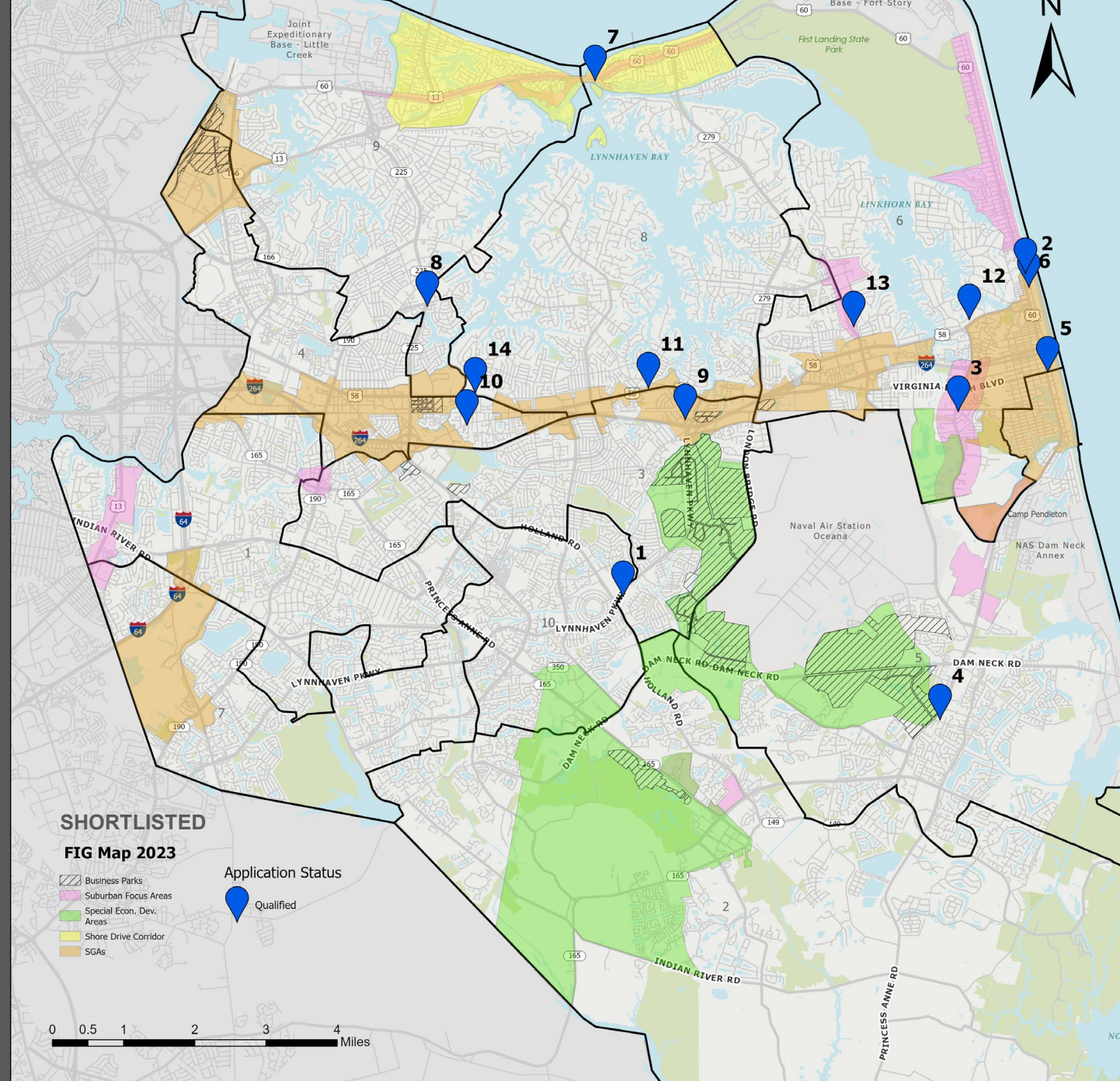



# 1. Cosmo's Corner, Inc.: 1136 Lynnhaven Parkway (Rank 4)

- **Disclosures Applicant/Owner:**

- ✓ Applicant Representative/President – Nicole Sincavage
- ✓ Officers/Members - Nicole Sincavage, Paul Sincavage
- ✓ Contractor – Taylor Construction; Engineer – Jakob Klein, American Engineering
- ✓ Banking – First Financial Bank – SBA
- ✓ Real Estate – John Duffy, Thalhimer
- ✓ Accounting – Jay Steer
- ✓ Architect – Monette Interiors, Karen Monette

- **Project Specifics**

- ✓ Repairing and painting facade
- ✓ Install two new hollow metal doors
- ✓ Repairing and repainting caps on top of the building
- ✓ Install signs and fence





# 1. Cosmo's Corner, Inc.: 1136 Lynnhaven Parkway



EXISTING FAÇADE

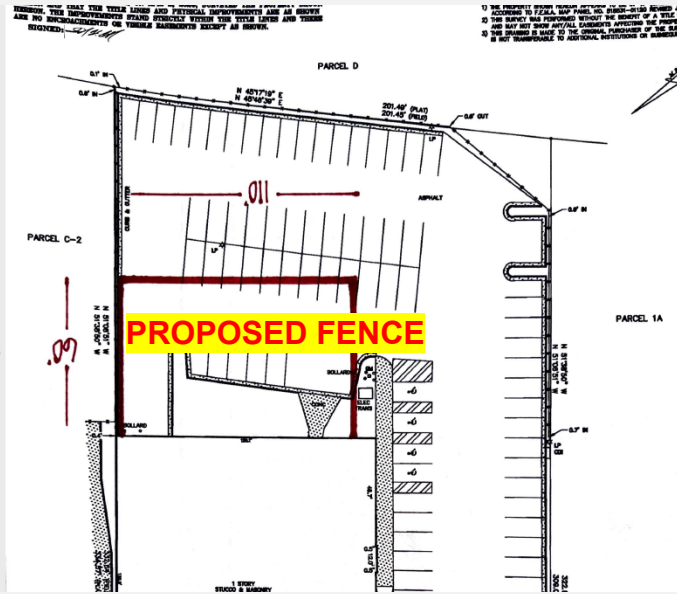

PROPERTY OF  
**Cardinal**  
 SIGN CORPORATION  
 2626 Dean Drive  
 Virginia Beach, Va. 23452  
 Phone: (757) 486-3412  
 Fax: (757) 486-7658  
 E-Mail: JPHELPS@CARDINALSIGN.COM  
 Client: Cosmo's Corner Doggie Daycare  
 Sign Location: 1136 Lynnhaven Pkwy Va Beach VA  
 Design No.: 31122  
 Designer: KD  
 Salesman: Jerry Phelps  
 Scale: 1/2"=1'-0"  
 Date: 1-28-23  
 Customer Approval: \_\_\_\_\_  
THIS DRAWING IS AN UNOFFICIAL PRELIMINARY DRAWING. IT IS NOT TO BE USED FOR CONSTRUCTION. ANY CHANGES TO THIS DRAWING WILL BE MADE AT THE CLIENT'S RISK AND WITHOUT NOTICE TO THE DESIGNER.

## PROPOSED SIGNS



SIGN A: LIGHTED WALL SIGN  
 - PANFORMED FACE  
 - VINYL GRAPHICS  
 84" X 126.6" = 73.85 SF



EXISTING (NTS)



PROPOSED (NTS)



SIGN B: LIGHTED WALL SIGN  
 - PANFORMED FACE  
 - VINYL GRAPHICS  
 84" X 126.6" = 73.85 SF



EXISTING (NTS)



PROPOSED (NTS)

Estimated Façade Investment: \$94,123

Grant Recommendation \$10,000

Total Estimated Investment: \$620,000

## 2. Ray Rays at the Mayflower, LLC: 209 34<sup>th</sup> Street (Rank 4)

- **Disclosures Applicant**

- ✓ Members/Officers – Raymond Labuen, Michael Shirmen
- ✓ Architect/Construction Contractor – Paul Van Auken, Van Auken Design and Build

- **Disclosures Owner**

- ✓ Owner – VTS Lynd Mayflower Owner, LLC
- ✓ Officers – Matthew Merritt, A. David Lynd
- ✓ Affiliations – VTS Lynd VA Beach Holdco, LLC, VTS Lynd JV VA Beach, LLC, VTS Lyn Investments VA Beach, LLC;
- ✓ Banking – Lument; Legal – Lippes Mathias, LLP
- ✓ Accounting – John Calhoun & Company

- **Project Specifics**

- ✓ Update patio in front of restaurant; new awning and sign
- ✓ Repaint and seal concrete floor
- ✓ Landscaping improvements around the entrance

District: 6





# 2. Ray Rays at the Mayflower LLC: 209 34<sup>th</sup> Street

EXISTING FAÇADE



PROPOSED IMPROVEMENTS

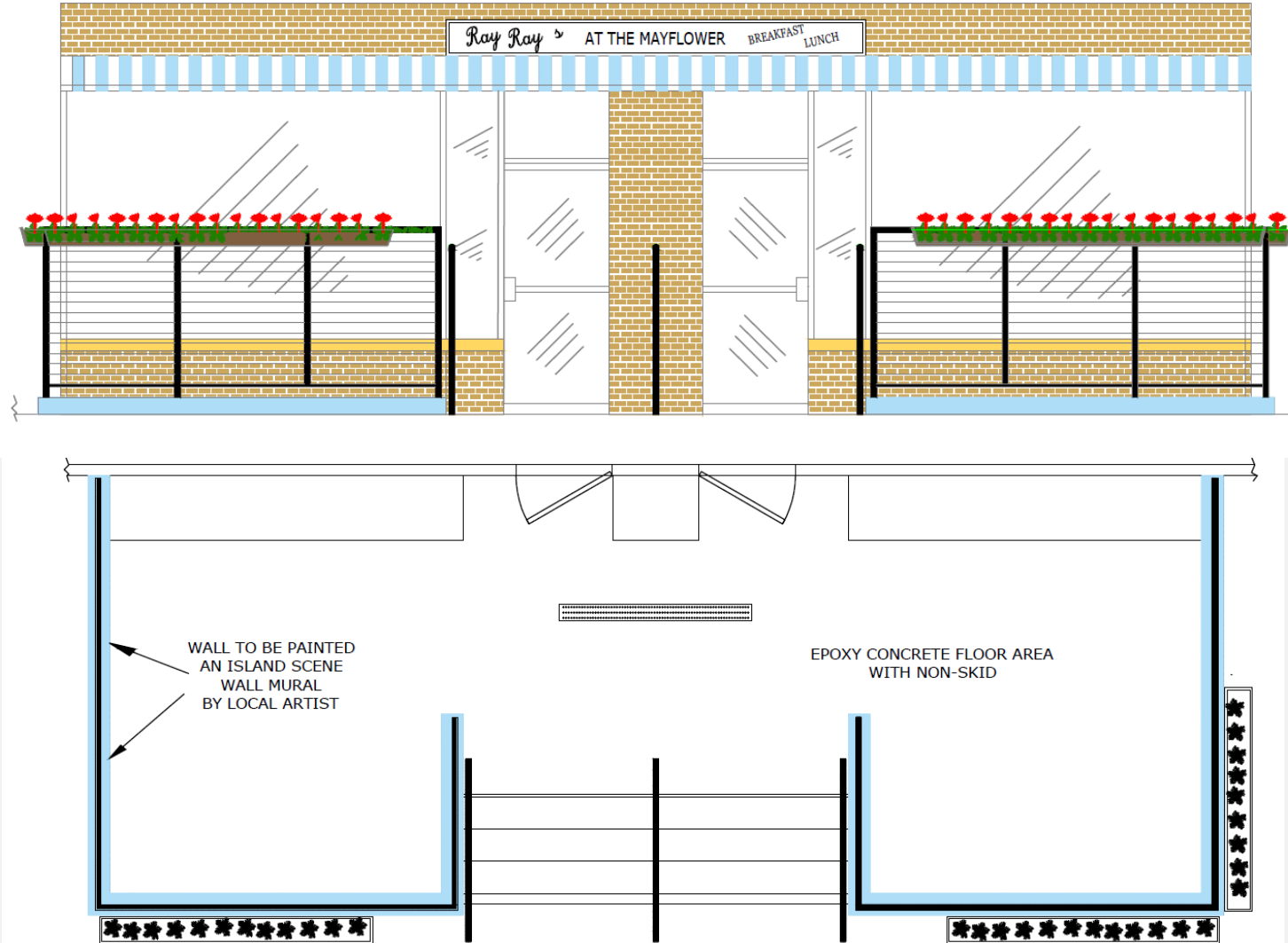

Estimated Investment: \$22,605  
Grant Recommendation: \$10,000

# 3. Aligned Chiropractic and Wellness, LLC: 1091 Norfolk Avenue (Rank 3)

- **Disclosures Applicant:**
  - ✓ Director – Ralph C.K. Nebling
- **Disclosures Owner:**
  - ✓ Property Owner – Mark Mousouris
  - ✓ Officers – Mark Mousouris, Denis Kapos
- **Project Specifics**
  - ✓ Installing a new sign





# 3. Aligned Chiropractic and Wellness, LLC: 1091 Norfolk Avenue



EXISTING SIGN



PROPOSED SIGN

Estimated Investment: \$5,395  
Grant Recommendation: \$2,697

District: 6



## 4. Mal-Bun Properties, LLC & Bunn Insurance Agency, Inc.: 1248 Culver Lane (Rank 3)

- **Disclosures Applicant**

- ✓ Applicant Representative – Tara Conneen
- ✓ Officers – David Bunn, President Bunn Insurance Agency
- ✓ Members - David Bunn, Mark Malbon, Michael Malbon, Mal-Bunn Properties, LLC
- ✓ Banking – TowneBank

- **Disclosures Owner**

- ✓ Property Owner – Mal-Bun Properties, LLC
- ✓ Banking – TowneBank

- **Project Specifics**

- ✓ Construct wooden fence behind office building
- ✓ Remove free standing sign & shrubbery (rear)
- ✓ Remove hedges in front of building-replace with new landscaping
- ✓ Replace 6 windows on the front of the building
- ✓ Enhance building sign





## 4. Mal-Bun Properties, LLC & Bunn Insurance Agency, Inc.: 1248 Culver Lane



Estimated Investment: \$18,800  
Grant Recommendation: \$9,400

District: 5



OPTION #1A:  
Logo Box - 31" Wide x 33" Tall  
Channel Letters - 22" Tall  
Light Box - 84" Wide x 9.5" Tall with 6" Copy  
Overall Dimensions - 120" Wide x 33" Tall





## 5. 1<sup>st</sup> Class Assets LLC, 223 17<sup>th</sup> Street (Rank 3)

- **Disclosures Applicant/Owner**

- ✓ CEO – Rhyan Finch
- ✓ Affiliate Business – 1<sup>ST</sup> Class Real Estate, LLC
- ✓ Financial – Southern Bank of Business
- ✓ Accounting – Barnes, Brock, Cornwell and Painter CPA
- ✓ Architect – EDC Homes Simpldsgn Engineering Services

- **Project Specifics**

- ✓ Updating the building structurally and externally
- ✓ New windows, doors, and walls
- ✓ Updating outdated structures and installing load-bearing structures

District: 5



# 5. 1<sup>st</sup> Class Assets, 223 17<sup>th</sup> Street

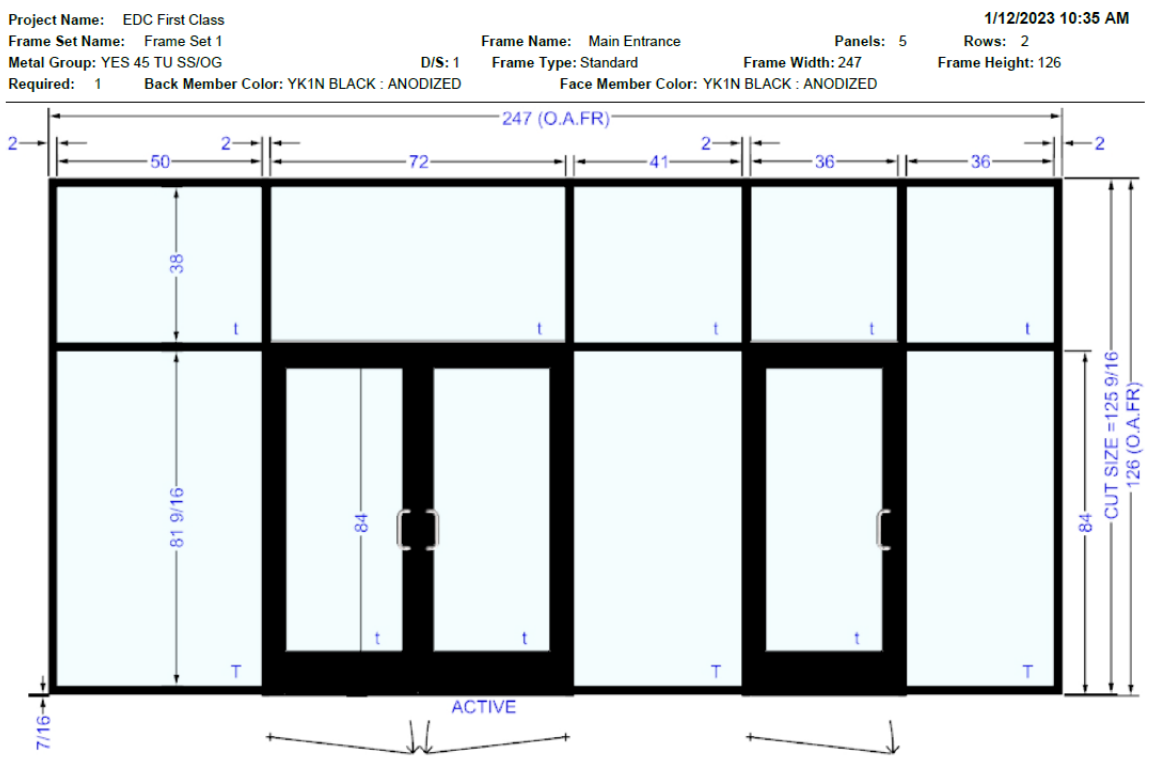

PROPOSED IMPROVEMENTS: MAIN ENTRANCE

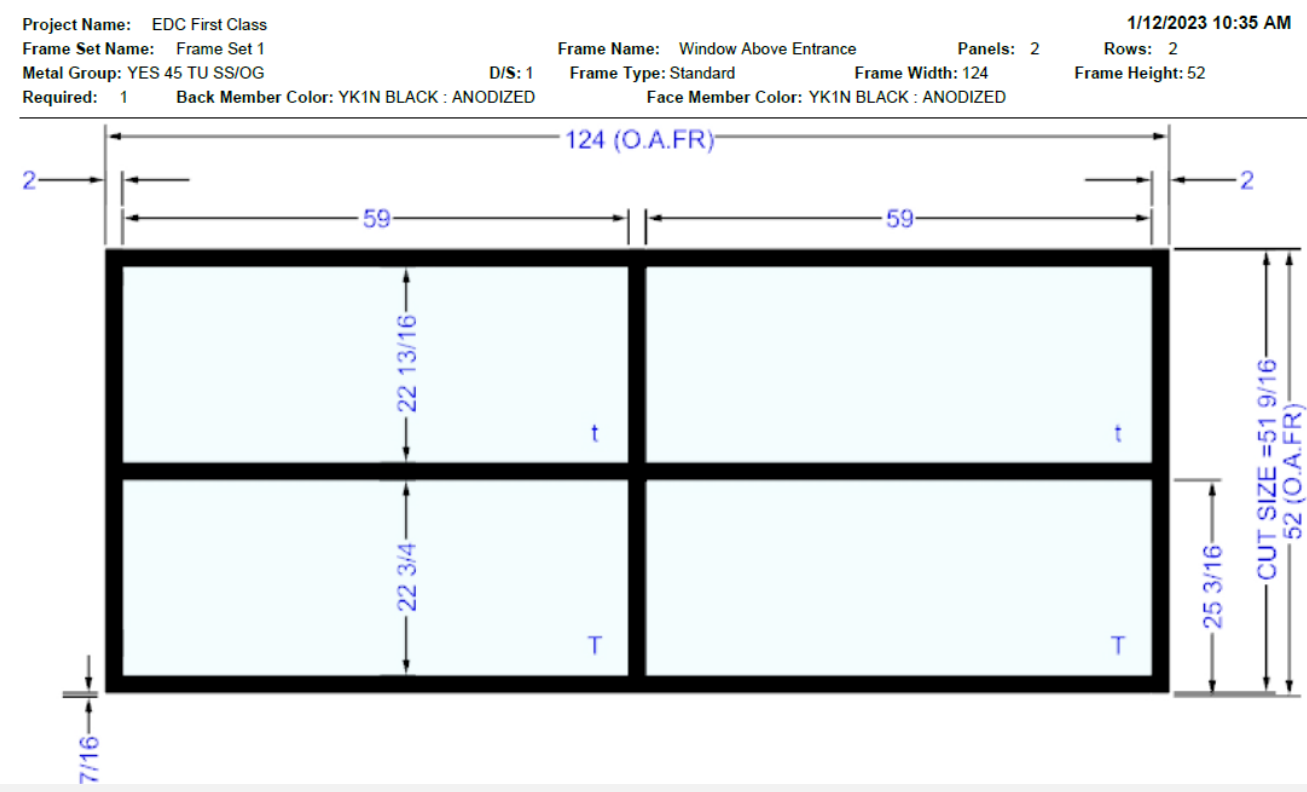

PROPOSED IMPROVEMENTS: LARGE WINDOWS ABOVE ENTRANCE



# 5. 1<sup>st</sup> Class Assets, 223 17<sup>th</sup> Street



EXISTING FAÇADE



PROPOSED IMPROVEMENTS

Estimated Façade Investment: \$22,174  
Grant Recommendation: \$10,000

Total Estimated Investment: \$750,000

# 6. Koch Development Corporation t/a Cutty Sark Motel & Cottages: 203 37<sup>th</sup> 1/2 St. (Rank 4)

- **Disclosures Applicant**

- ✓ Officer/Director – Jimmie A. Koch
- ✓ Accounting – Sandy Jackson, SWJ Bookkeeping Inc.
- ✓ Contractor – Henlee Construction Corp.

- **Disclosures Owner:**

- ✓ Owner - JAMAK, LLC

- **Project Specifics**

- ✓ Remove and install brick molding and storm windows
- ✓ Paint and power wash exterior
- ✓ Install new vinyl railing at the front door

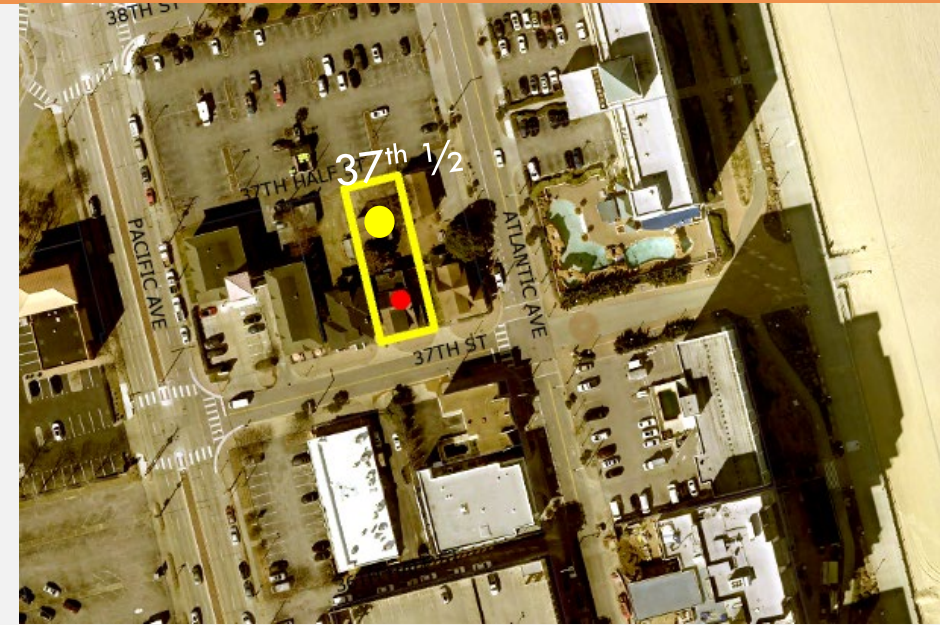



# 6. Koch Development Corporation t/a Cutty Sark Motel & Cottages: 203 37<sup>th</sup> 1/2 St



EXISTING FAÇADE

Estimated Investment:

\$11,100

Grant Recommendation:

\$5,550



# 7. The Lesner Inn & Catering Club: 3319 Shore Drive (Rank 3)

- **Disclosures Applicant:**

- ✓ Applicant Representative – Dimitri Hionis
- ✓ Affiliations – Bubba’s Marina Inc.
- ✓ Accounting – Zukerman & Associates
- ✓ Contractor – Coastal Design Group, Glass Corporation

- **Disclosures Owner:**

- ✓ Owner - Harbor Preserve, LLC
- ✓ Officer - Dimitri Hionis

- **Project Specifics**

- ✓ Possibly rebrand/rename the venue to “Shutters on the Inlet”
- ✓ New front doors & new awning
- ✓ Replace existing exterior entry doors
- ✓ Structural improvements to the entrance

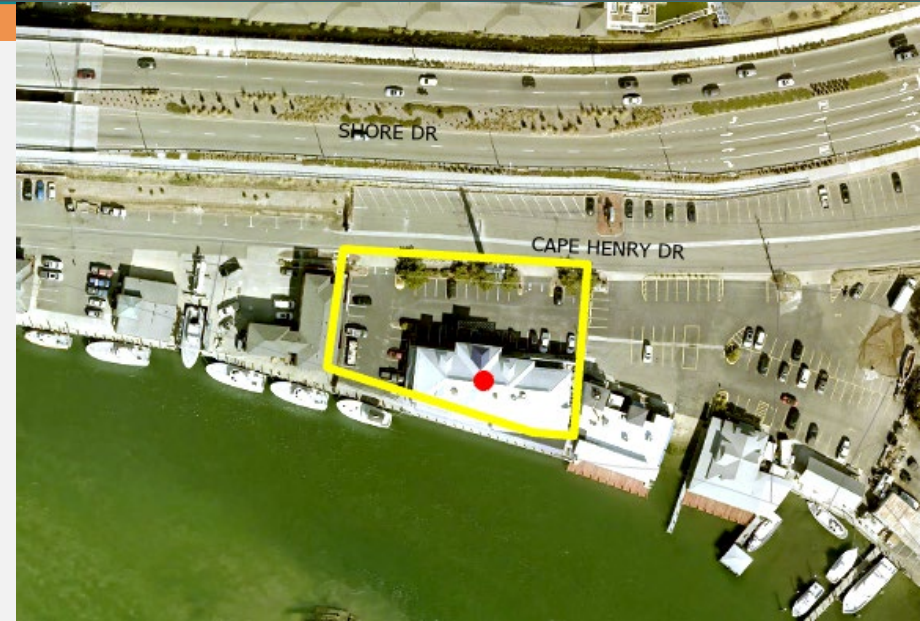

# 7. The Lesner Inn Catering Club: 3319 Shore Drive

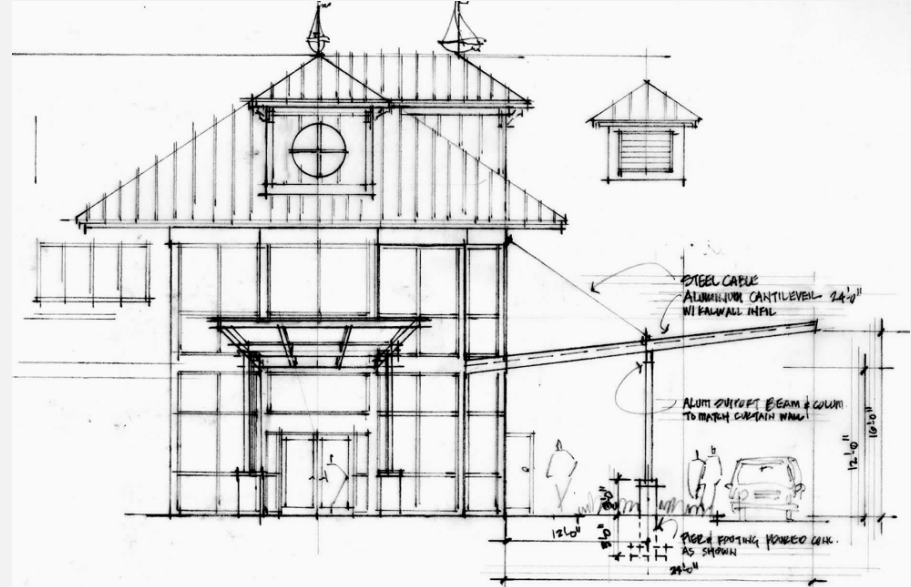
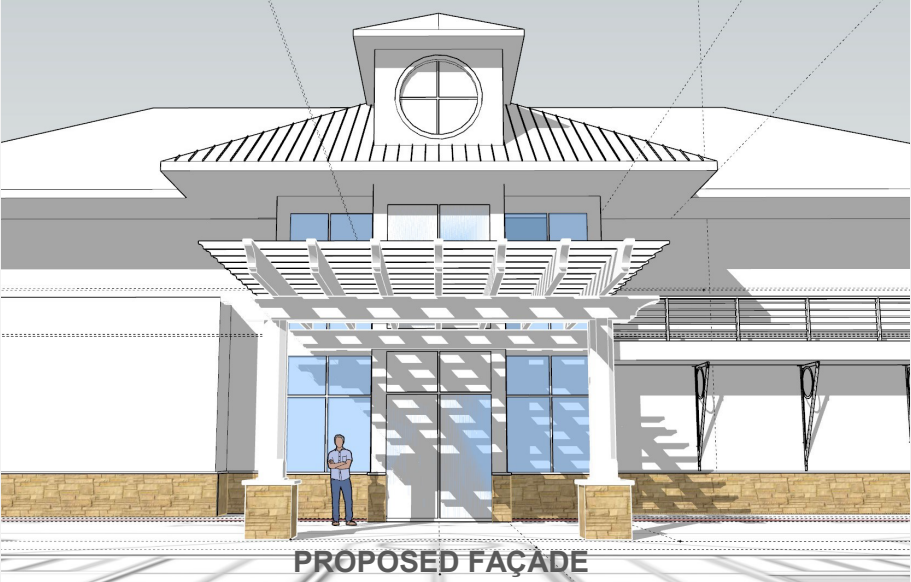



# 7. The Lesner Inn & Catering Club: 3319 Shore Drive

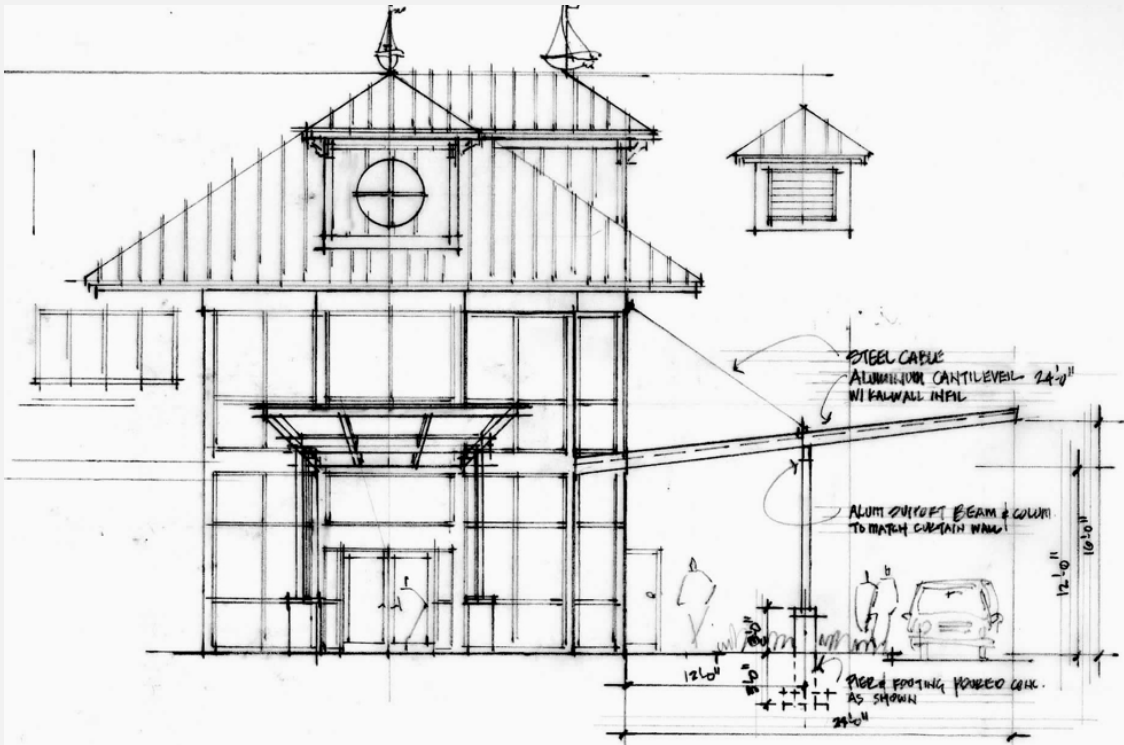

Estimated Investment: \$20,901  
 Grant Recommendation: \$10,000

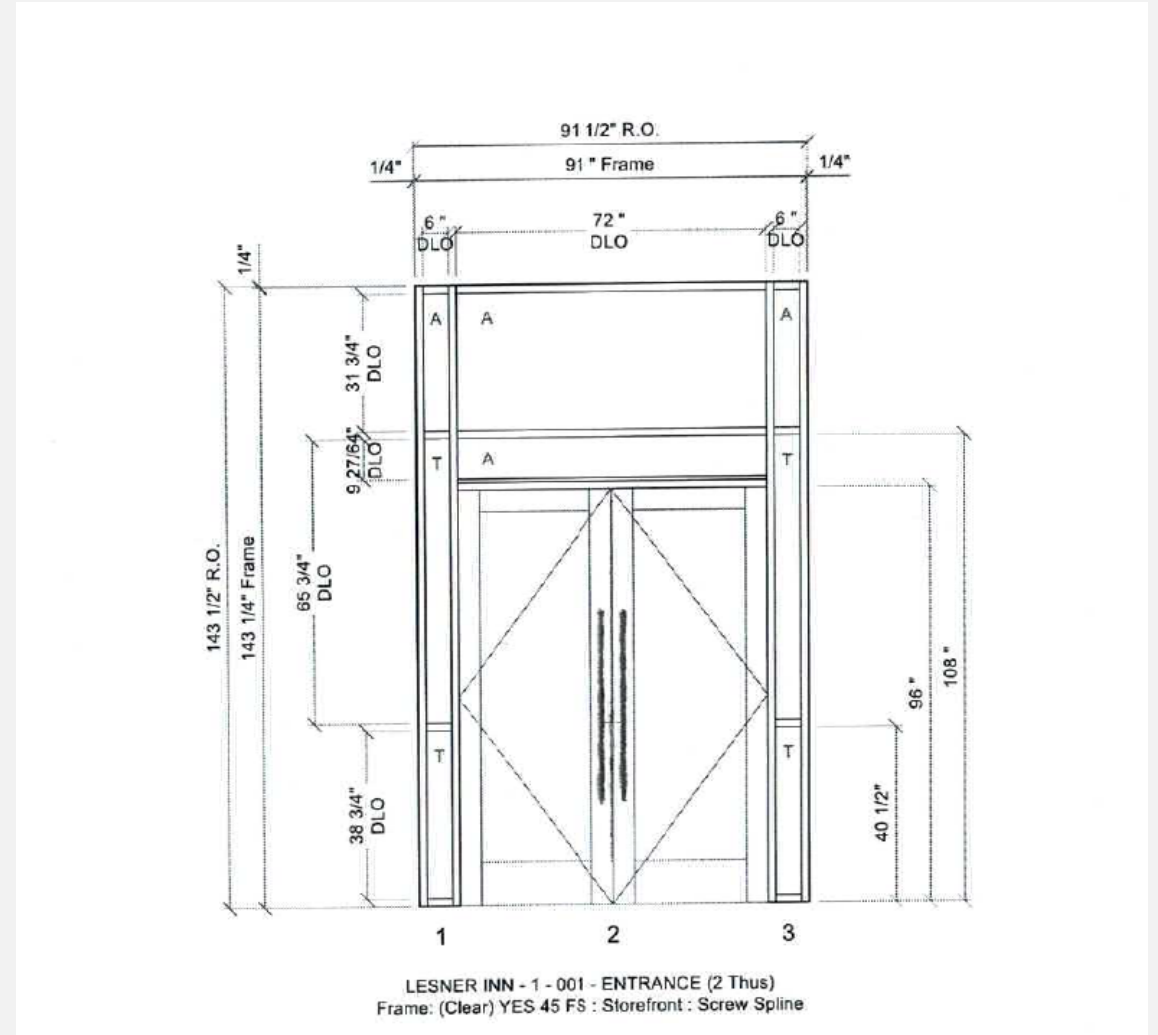

# 8. Lakeshore Property, LLC: 700 Independence Cir. (Rank 4)

- **Disclosures Applicant/Owner:**

- ✓ Owner – Amrish Patel
- ✓ Banking – Southern Bank
- ✓ Accountant – Chirag Patel

- **Project Specifics**

- ✓ Install 9 parking lot lights, new light poles and heads and electrical connections





# 8. Lakeshore Property, LLC: 700 Independence Cir.

- **Tenants:**

- ✓ Ste. 1A – Lakeshore Dental – 7 Employees
- ✓ Ste. 1D – Total Care for Women – 6 Employees
- ✓ Ste. 2B – Therafusion Massage – 4 Employees
- ✓ Ste. 2C – Pure Clinical Skin Care – 2 Employees
- ✓ Ste. 2D – Atlantic Ophthalmology – 3 Employees
- ✓ Ste. 3D – Dr. Kaloji Sleep Center – 4 Employees

Estimated Investment: \$19,800

Grant Recommendation: \$9,900



EXISTING



# 9. Dan Miller & Associates PC dba Law Offices of Daniel J. Miller: 2725 Gator Street (Rank 3)

- **Disclosures Applicant**

- ✓ Applicant Representative – Daniel J. Miller
- ✓ Banking – TowneBank
- ✓ Contractor – Mike Harrington

- **Disclosures Owner**

- ✓ Owner – Gator Road, LLC

- **Project Specifics**

- ✓ Paint brick exterior
- ✓ Replace current sign (rear facing 264)

District: 3



# 9. Dan Miller & Associates PC dba Law Offices of Daniel J. Miller: 2725 Gator Street



EXISTING FAÇADE

Estimated Investment: \$20,957  
**Grant Recommendation: \$10,000**

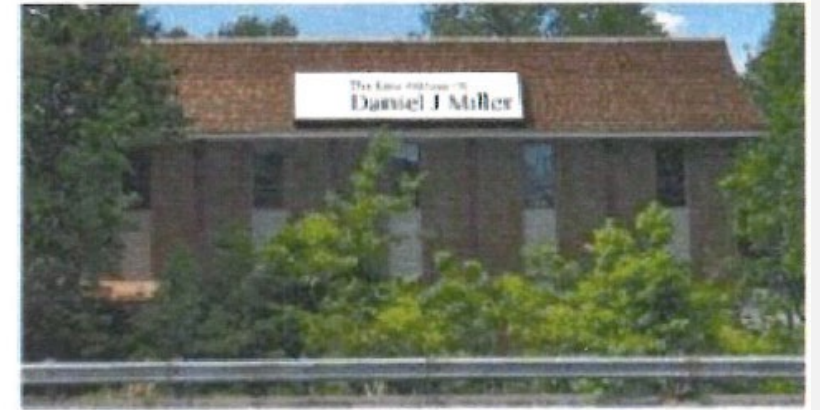

EXISTING SIGN



PROPOSED SIGN



# 10. Wealth Avenue: 4317 Bonney Rd. (Rank 4)

- **Disclosures Applicant:**

- ✓ Officers/Members – Philip Maliniak, Xerxes Nabong
- ✓ Accounting – John Gray, Gray CPA
- ✓ Legal Services – Greg Montero, Inman & Strickler

- **Disclosures Owner:**

- ✓ Property Owner – Greenwich Partners
- ✓ Members: Philip Maliniak, Xerxes Nabong, Margaret Little, Tim Little
- ✓ Banking – TowneBank
- ✓ Accounting – COVA CPA Group
- ✓ Legal – Greg Montero, Inman & Strickler





# 10. Wealth Avenue: 4317 Bonney Rd.

- **Project Specifics**

- ✓ Landscaping enhancements:

- Installing a border to help maintain the front façade
- Installing bushes, and sod to increase the curb appeal of the building

Estimated Investment:           \$3,865

Grant Recommendation:       \$1,931





# 11. Assisi Medical Services dba Veterinary Hospital of Virginia Beach: 3002 Va Beach Blvd. (Rank 4)

- **Disclosures Applicant:**

- ✓ Applicant Representative – Andrew Silverstone, DVM

- **Disclosures Owner:**

- ✓ Owner – William A. Webb
- ✓ Accounting – Jones CPA

- **Project Specifics**

- ✓ Exterior paint of walls, decks
- ✓ Repair fence; replace gutters
- ✓ New LED lights on sign “Animal Hospital”
- ✓ Expand outdoor exam room
- ✓ Replace windows with energy efficient units
- ✓ Build a walkway from the front parking lot to the rear of the building.
- ✓ Landscaping improvements will be required for safety and aesthetics (including additional exterior lighting)

District: 8





# 11. Assisi Medical Services dba Veterinary Hospital of Virginia Beach: 3002 Va Beach Blvd.

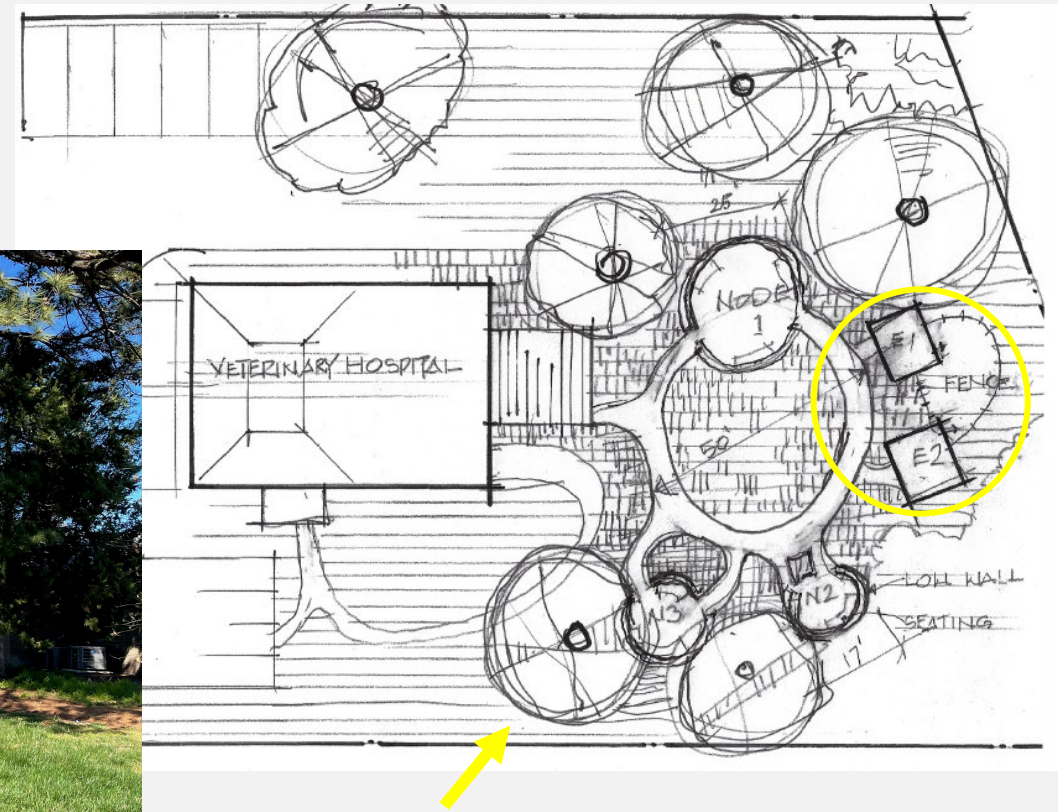

Estimated Investment: \$48,247  
Grant Recommendation: \$10,000



# 1 2. Lynnhaven International, LLC: 1072 Laskin Rd. (Rank 3)

- **Disclosures Applicant/Owner**

- ✓ Owner – John Feigenbaum
- ✓ Members – John Feigenbaum, James Halperin, Steven Ivy
- ✓ Affiliation – CDN Publishing LLC
- ✓ Accounting – Dasha Payne, Wall, Einhorn & Chernitzer
- ✓ Contractor – Rick Stageburg, Lakewood Builders
- ✓ Legal – Alan Frieden, Faggert & Frieden

- **Project Specifics**

- ✓ Renovation of staircase treads, risers and installation of low voltage riser lighting
- ✓ Replacement of all (98) windows to new vinyl Simonton windows and new Everlast siding and window trim.





# 12. Lynnhaven International: 1072 Laskin Rd.



EXISTING FAÇADE

# 1 2. Lynnhaven International, LLC: 1072 Laskin Rd.

- **Tenants**

- ✓ CDN Publishing, LLC : 9 employees
- ✓ Seaside Behavioral Health, LLC : 8 employees
- ✓ Events Management Group: 3 employees
- ✓ Kapital Management, LLC : 2 employees
- ✓ Hudgins Realty: 2 employees

Estimated Investment:            \$122,420  
Grant Recommendation:        **\$10,000**





# 13. Jim White Fitness & Nutrition, Inc. dba Jim White Fitness Studios: 848 First Colonial Rd. (Rank 3)

- **Disclosures Applicant:**

- ✓ Applicant Representative – Jim White
- ✓ Affiliation – Jim White Fitness & Nutrition, Inc. dba Jim White Fitness Studios
- ✓ Banking – TowneBank
- ✓ Accounting – Jones CPA
- ✓ Architect – Atlantic Outdoor, LLC

- **Disclosures Owner:**

- ✓ Owner – 848 Properties, LLC

- **Project Specifics**

- ✓ Building pressure washing and updating landscaping at the front facing First Colonial Rd.

District: 6





# 13. Jim White Fitness & Nutrition, Inc. dba Jim White Fitness Studios: 848 First Colonial Rd.



EXISTING FAÇADE

Estimated Investment: \$7,688  
Grant Recommendation: \$3,844





# 14. Pacific Moon Sun, LLC dba Koco Korean Fried Chicken & Croffles: 4224 Virginia Beach Blvd. (Rank 4)

- **Disclosures Applicant:**

- ✓ Applicant Representative – Linda Tran

- **Disclosures Owner**

- Owner - Willis Realty Corp.
  - President – Ben Willis
  - Banking – Southern Bank

- **Project Specifics**

- ✓ Installing two building signs: front and rear facing Virginia Beach Blvd.

District: 8



EXISTING FAÇADE



# 14. Pacific Moon Sun, LLC dba Koco Korean Fried Chicken & Croffles: 4224 Virginia Beach Blvd.



EXISTING FAÇADE



PROPOSED SIGN (FRONT)



PROPOSED SIGN (REAR)

Estimated Investment:

\$12,122

Grant Recommendation:

\$6,061



## Recommendation

- *Recommend approval of 14 award requests in the amount of \$109,385 as presented and advance the remaining applicant to the next VBDA meeting*



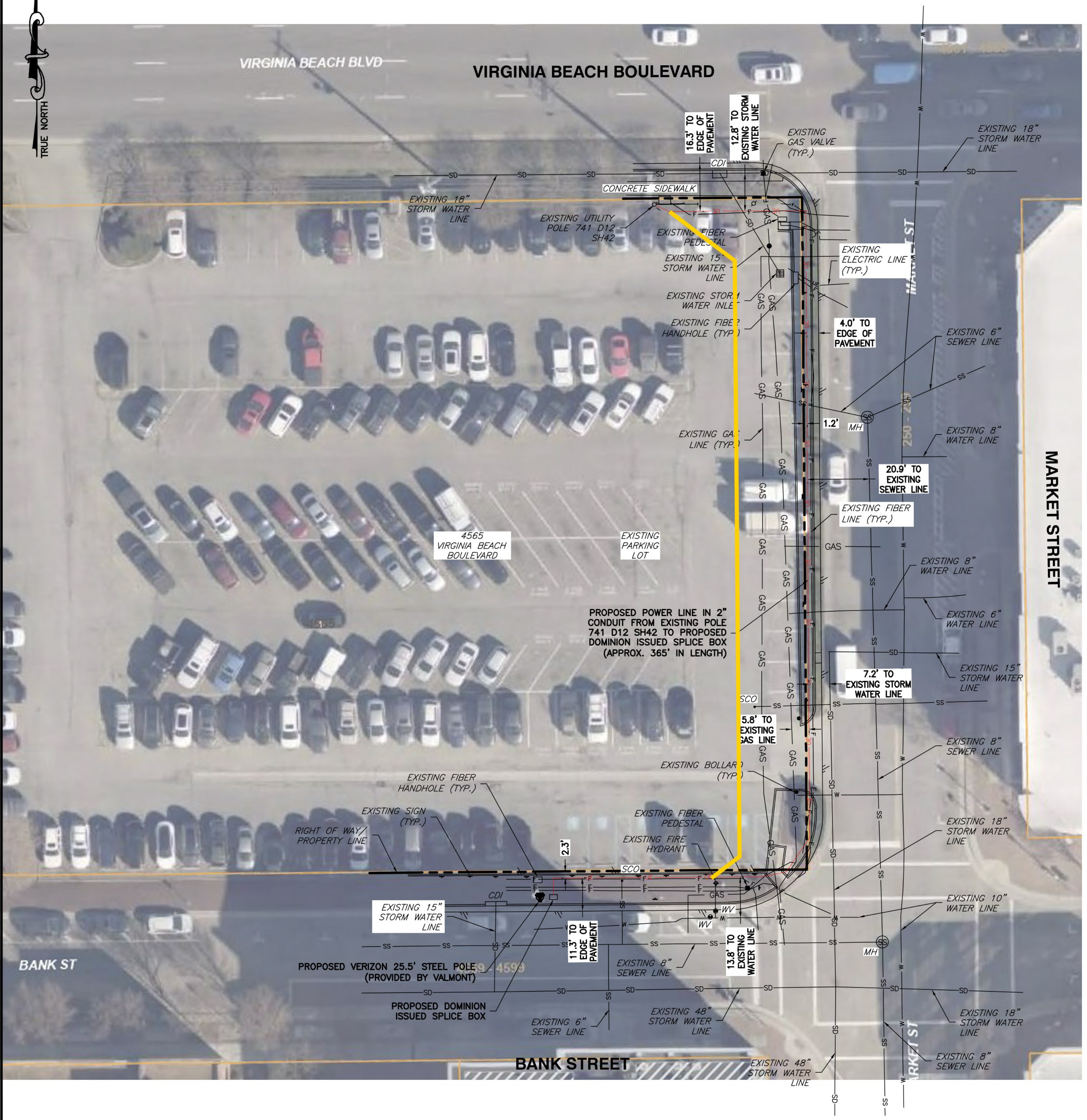

1 RIGHT-OF-WAY UTILITY EXHIBIT  
Z-2 SCALE: 1" = 20'

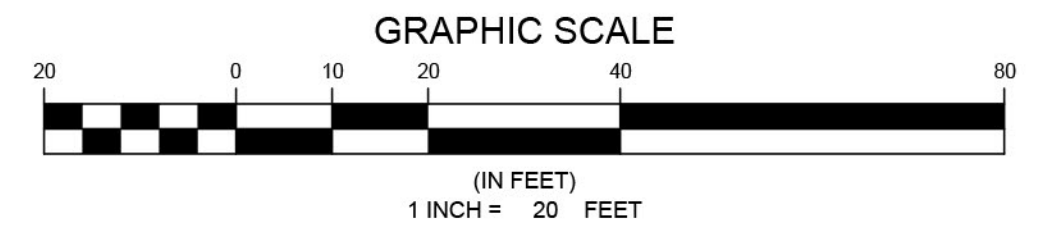

**GENERAL NOTES**

1. THIS PLAN IS SUBJECT TO ALL EASEMENTS AND RESTRICTIONS OF RECORD.
2. NO SIGNIFICANT NOISE, SMOKE, DUST, OR ODOR WILL RESULT FROM THIS FACILITY.
3. THE FACILITY IS UNMANNED AND NOT INTENDED FOR HUMAN HABITATION. THERE IS NO HANDICAP ACCESS REQUIRED.
4. THE FACILITY IS UNMANNED AND DOES NOT REQUIRE POTABLE WATER OR SANITARY SERVICE.
5. THE EXISTING UTILITY INFORMATION SHOWN REPRESENTS THE BEST DATA AVAILABLE FROM EXISTING DOCUMENTATION AND FIELD EVIDENCE. ALL LOCATIONS SHOULD BE CONSIDERED APPROXIMATE, AND A FIELD INVESTIGATION MUST BE PERFORMED IN THE VICINITY OF ANY CONSTRUCTION ACTIVITIES. NOTE THAT THESE PLANS MAY NOT SHOW ALL UTILITIES THAT ARE PRESENT AT THE SITE.

**NOTE:**  
BEFORE ANY GROUND IS DISTURBED, THE CONTRACTOR MUST HAVE A UTILITY LOCATE MARK THE GROUND WITH ANY EXISTING UNDERGROUND UTILITIES IN THE AREA OF THE PROPOSED SITE.



- (i) The line's owner is responsible for all costs to move it when this property gets developed;
- (ii) The disruption to the parking lot is minimal (via boring ideally) and anything disturbed is returned to current or improved state;
- (iii) Can continue to be utilized for parking; &
- (iv) The existing hedge line along Market Street remains undisturbed.

**NB+C**  
TOTALLY COMMITTED.  
NB+C ENGINEERING SERVICES, LLC.  
120 EASTSHORE DRIVE, SUITE 300  
GLEN ALLEN, VA 23059

**verizon**  
1831 RADY COURT  
RICHMOND, VA 23222

CHINESE CORNER VABTC 001  
NB+C PROJECT #:100356  
VERIZON WIRELESS  
4565 VIRGINIA BEACH BLVD  
VIRGINIA BEACH, VA 23462  
CITY OF VIRGINIA BEACH

**REVISIONS**

REV	DATE	DESCRIPTION	BY
2	09/20/21	RIGHT-OF-WAY EXHIBIT	KAG
1	05/08/20	REVISED	KLB
0	11/06/19	FINAL	KAG

PROFESSIONAL STAMP

ENGINEER  
TRENT T. SNARR, P.E.  
VA PROFESSIONAL ENGINEER LIC. #49978

SHEET TITLE  
**UNDERGROUND POWER SUPPLY DETAIL**

SHEET NUMBER  
**E-3**

